



2SC1384 (3DA1384)

硅 NPN 半导体三极管/SILICON NPN TRANSISTOR

用途:用于音频功率放大和驱动。

Purpose: AF power amplifier and driver applications.

特点:饱和压降低,与 2SA684(3CA684) 互补可得 2~3 瓦输出。

Features: Low $V_{CE(sat)}$, 2~3W output in complementary pair with 2SA684(3CA684).

极限参数/Absolute maximum ratings ($T_a=25^\circ\text{C}$)

参数符号 Symbol	数值 Rating	单位 Unit
V_{CBO}	60	V
V_{CEO}	50	V
V_{EBO}	5.0	V
I_C	1.0	A
I_{CP}	1.5	A
P_C	1.0	W
T_j	150	$^\circ\text{C}$
T_{stg}	-55~150	$^\circ\text{C}$

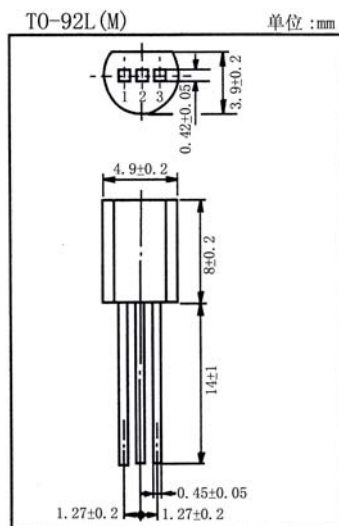

引脚: 1.E 2.C 3.B

电性能参数/Electrical characteristics ($T_a=25^\circ\text{C}$)

参数符号 Symbol	测试条件 Test condition		数值 Rating			单位 Unit
			最小值 Min	典型值 Typ	最大值 Max	
V_{CBO}	$I_C=10\ \mu\text{A}$	$I_E=0$	60			V
V_{CEO}	$I_C=2.0\text{mA}$	$I_B=0$	50			V
V_{EBO}	$I_E=10\ \mu\text{A}$	$I_C=0$	5.0			V
I_{CBO}	$V_{CB}=20\text{V}$	$I_E=0$			0.1	μA
$h_{FE(1)}$	$V_{CE}=10\text{V}$	$I_C=500\text{mA}$	85	160	340	
$h_{FE(2)}$	$V_{CE}=5.0\text{V}$	$I_C=1.0\text{A}$	50	100		
$V_{CE(sat)}$	$I_C=500\text{mA}$	$I_B=50\text{mA}$		0.2	0.4	V
$V_{BE(sat)}$	$I_C=500\text{mA}$	$I_B=50\text{mA}$		0.85	1.2	V
f_T	$V_{CE}=10\text{V}$	$I_C=50\text{mA}$		200		MHz
C_{ob}	$V_{CB}=10\text{V}$	$I_E=0$	$f=1.0\text{MHz}$	11	20	pF

$h_{FE(1)}$ 分档/ $h_{FE(1)}$ classifications: Q: 85~170 R: 120~240 S: 170~340



2SC1384 (3DA1384)

